

**DIVISION: 05 00 00—METALS**  
**Section: 05 50 00—Metal Fabrications**

**REPORT HOLDER:**

**TIGER BRAND JACK POST COMPANY**

**EVALUATION SUBJECT:**

**TIGER BRAND FIXED AND ADJUSTABLE COLUMNS**

## 1.0 EVALUATION SCOPE

**Compliance with the following codes:**

- 2009 *International Building Code*® (2009 IBC)
- 2009 *International Residential Code*® (2009 IRC)
- 2006 *International Building Code*® (2006 IBC)
- 2006 *International Residential Code*® (2006 IRC)
- 2013 *Abu Dhabi International Building Code* (ADIBC)†

†The ADIBC is based on the 2009 IBC. 2009 IBC code sections referenced in this report are the same sections in the ADIBC.

**Property evaluated:**

Structural

## 2.0 USES

Tiger Brand Fixed and Adjustable Columns are steel prefabricated columns for use as structural members to transfer axial compressive loads from steel or wood beams to concrete foundation.

## 3.0 DESCRIPTION

### 3.1 Adjustable Columns:

Table 1 lists the dimensions of the various adjustable columns manufactured by Tiger Brand Jack Post Company. All are available in ASTM A 500 Grade B (42 ksi yield strength). The 3<sup>1</sup>/<sub>2</sub>-inch diameter by 0.216 inch thick column is also available in Grade A (33 ksi yield strength). All are available in 6 foot to 12 foot lengths.

### 3.2 Fixed Columns:

Fixed columns are the same as the adjustable columns, without the adjusting mechanism. They are available with a minimum 0.120-inch-thick ASTM A 1011 CS Type B steel plate welded to each end, or with one plate welded to one end and the other plate attached by straps (to be welded to the column after sizing in the field; see Section 4.3).

## 4.0 INSTALLATION

### 4.1 Design:

The available concentric axial compressive strengths for adjustable and fixed columns are noted in Tables 2 and 3, for both allowable strength (ASD) and design strength (LRFD). The actual axial compressive load applied to the adjustable or fixed columns must be less than the allowable strength or design strength loads, as applicable, specified in this report. The capacity of the end plates must be calculated in accordance with applicable code requirements for the steel, concrete or wood to determine whether the supplied end plate thickness is adequate for the applied load interface (wood beams, steel beams or concrete).

### 4.2 Installation:

Installation of the Tiger Brand Adjustable and Fixed Columns described in this report must comply with this report and the manufacturer's published installation instructions. The manufacturer's published installation instructions and engineering drawings must be available at the jobsite at all times during installation. When the manufacturer's published installation instructions differ from this report, this report governs.

Tiger Brand Adjustable and Fixed Columns must be installed vertically with the bottom supported by a foundation capable of supporting the imposed loads. Adjustable columns must be adjusted to the desired length. The adjustable columns are installed with the adjustment screw at the base. After installation, the adjustment assembly must be encased in concrete to prevent movement after installation. Fixed columns are sized by cutting the un-plated end of the post. The cut end of the post must be smooth and level in order to fit flush with the end plate.

### 4.3 Special Inspection:

Field-welding of end plate to post requires special inspection in accordance with IBC Section 1704.3 and Table 1704.3. The weld material used must be E70XX or E60XX, with the welds conforming with the procedures given in AWS D1.1 or AWS D1.3. Special inspection in accordance with Section 1704 of the IBC must be provided for field-welding under the IRC. The code official must receive a report, from an approved special inspector, that includes the following details:

1. The post description, including the product name, series number, initial length, final length, plate size and thickness.

2. Verification of visual inspection, welding material used, storage conditions for weld material, joint preparation, conformance of weld procedures with AWS D1.1 or D1.3 (depending on thickness of material) and size and type of weld.
3. Installation description, including verification of full bearing of post on plate and orientation of plate to post (the plate is at a 90-degree angle to the axis of the post).

**5.0 CONDITIONS OF USE**

The Tiger Brand Adjustable and Fixed Columns described in this report comply with, or are suitable alternatives to what is specified in, those codes listed in Section 1.0, subject to the following conditions:

- 5.1 Tiger Brand adjustable and fixed columns must be fabricated and installed in accordance with this report, the manufacturer’s published installation instructions and the applicable code. In the event of a conflict between the manufacturer’s published installation instructions and this report, this report governs
- 5.2 Where required by the code official or this report, engineering calculations and construction documents consistent with this report must be submitted for approval. The documents must contain details of the attachment to the structure consistent with the requirements of this report. The documents must be prepared by a registered design professional where required by the statutes of the jurisdiction in which the project is to be constructed.
- 5.3 Loading on adjustable and fixed columns must be limited to the maximum concentric axial compressive loads indicated in Tables 2 and 3. Other loading conditions, such as (but not limited to) eccentric loads, tensile axial loads, bending loads, and lateral loads, are beyond the scope of this report.

- 5.4 Connections of the post to the foundation and the supported construction are outside the scope of this report and must be approved by the code official.
- 5.5 Maximum adjustment of the adjustable columns is 4 inches (102 mm) and the overall column height must be limited to the maximum height. Adjustable columns must be limited to the maximum lengths given in Table 2.
- 5.6 Tiger Brand Adjustable and Fixed Columns are manufactured at Meadville, Pennsylvania, under a quality control program with inspections by ICC-ES.

**6.0 EVIDENCE SUBMITTED**

Data and test reports in accordance with the ICC-ES Acceptance Criteria for Adjustable Steel Columns (AC335) dated February 2008 (Editorially revised March 2011).

**7.0 IDENTIFICATION**

All Tiger Brand Adjustable and Fixed Columns are marked at the plant with the manufacturer’s name post diameter, thickness, allowable concentric axial compressive load, strength design load, specified yield strength of the post material, model number, and the evaluation report number (ESR-1766).

- 7.1 The report holder’s contact information is the following:

**TIGER BRAND JACK POST COMPANY**  
**10721 SOUTH WATER STREET**  
**MEADVILLE, PENNSYLVANIA 16335**  
**(814) 333-4302**  
[www.tigerbrandjackpost.com](http://www.tigerbrandjackpost.com)  
[pbosela@tapcocompanies.com](mailto:pbosela@tapcocompanies.com)

**TABLE 1—DIMENSIONAL PROPERTIES ADJUSTABLE AND FIXED COLUMNS**

Nominal Tube Diameter	3 in.		3½ in.		4 in.	
Nominal tube thickness	0.120 in.	0.120 in.	0.216 in.	0.120 in.	0.226 in.	
Top plate (H plate or standard plate)	H Plate ASTM A 1011 CS Type B Steel 0.120 minimum thickness See Figure 1 for dimensions.					
	Standard Plate ASTM A 1011 CS Type B Steel 0.120 minimum thickness See Figure 1 for dimensions.					
Minimum Plate thickness	0.120 in.	0.120 in.	0.200 in.	0.120 in.	0.250 in.	
Adjustment Mechanism						
“Shoulder nut” thickness	¾ in.	¾ in.	1 in.	¾ in.	1½ in.	
Adjusting screw Outside Diameter (O.D.)	1¼ in.	1¼ in.	1½ in.	1¼ in.	1½ in.	
Minimum Swivel plate thickness	0.120 in.	0.120 in.	0.200 in.	0.120 in.	0.25 in.	
Handle to adjust the screw	15/32 in. diameter by 7 in. length					

For SI: 1 inch = 25.4 mm.

TABLE 2—LOAD CAPACITIES OF ADJUSTABLE COLUMNS<sup>1,2,3</sup>

Dia (in)	3		3.5		3.5		3.5		4		4	
Nom, thickness (in)	0.12		0.12		0.216		0.216		0.12		0.226	
Design thickness (in)	0.112		0.112		0.201		0.201		0.112		0.210	
Fy (ksi)	42		42		33		42		42		42	
Capacity (kips)												
Max length (in)	LRFD $\Phi_c P_n$	ASD $P_a$	LRFD $\Phi_c P_n$	ASD $P_a$	LRFD $\Phi_c P_n$	ASD $P_a$	LRFD $\Phi_c P_n$	ASD $P_a$	LRFD $\Phi_c P_n$	ASD $P_a$	LRFD $\Phi_c P_n$	ASD $P_a$
76	20.3	13.5	25.6	17.0	36.0	23.9	44.0	29.3	30.7	20.4	55.3	36.8
79	19.9	13.3	25.2	16.8	35.6	23.7	43.3	28.8	30.4	20.2	54.7	36.4
82	19.5	13.0	24.8	16.5	35.1	23.4	42.6	28.4	30.0	20.0	54.1	36.0
85	19.1	12.7	24.5	16.3	34.7	23.1	41.9	27.9	29.7	19.7	53.4	35.5
88	18.6	12.4	24.1	16.0	34.2	22.8	41.2	27.4	29.3	19.5	52.7	35.1
91	18.2	12.1	23.6	15.7	33.8	22.5	40.5	26.9	28.9	19.3	52.0	34.6
94	17.7	11.8	23.2	15.5	33.3	22.1	39.7	26.4	28.6	19.0	51.3	34.1
97	17.3	11.5	22.8	15.2	32.8	21.8	39.0	25.9	28.2	18.7	50.6	33.6
100	16.8	11.2	22.4	14.9	32.3	21.5	38.2	25.4	27.8	18.5	49.8	33.1
103	16.3	10.9	21.9	14.6	31.8	21.1	37.4	24.9	27.4	18.2	49.1	32.6
106	15.9	10.6	21.5	14.3	31.2	20.8	36.6	24.4	26.9	17.9	48.3	32.1
109	15.4	10.2	21.0	14.0	30.7	20.4	35.8	23.8	26.5	17.6	47.5	31.6
112	14.9	9.9	20.6	13.7	30.2	20.1	35.0	23.3	26.1	17.4	46.7	31.1
115	14.4	9.6	20.1	13.4	29.6	19.7	34.1	22.7	25.7	17.1	45.9	30.5
118	14.0	9.3	19.6	13.1	29.1	19.3	33.3	22.2	25.2	16.8	45.0	30.0
121	13.5	9.0	19.2	12.8	28.5	19.0	32.5	21.6	24.8	16.5	44.2	29.4
124	13.0	8.7	18.7	12.4	27.9	18.6	31.6	21.0	24.3	16.2	43.4	28.8
127	12.5	8.3	18.2	12.1	27.4	18.2	30.8	20.5	23.9	15.9	42.5	28.3
130	12.1	8.0	17.7	11.8	26.8	17.8	29.9	19.9	23.4	15.6	41.6	27.7
133	11.6	7.7	17.3	11.5	26.2	17.4	29.1	19.3	22.9	15.3	40.8	27.1
136	11.1	7.4	16.8	11.2	25.6	17.0	28.2	18.8	22.5	14.9	39.9	26.5
139	10.7	7.1	16.3	10.8	25.0	16.6	27.4	18.2	22.0	14.6	39.0	25.9
142	10.2	6.8	15.8	10.5	24.4	16.3	26.5	17.6	21.5	14.3	38.1	25.4
145	10.0	6.6	15.4	10.2	23.8	15.9	25.7	17.1	21.0	14.0	37.2	24.8

For **SI**: 1 inch = 25.4 mm; 1 kip = 1000 lbf = 4.45 Kn.

**Notes:**

<sup>1</sup>This is based on standard installation, which assumes that the ends are supported such that both ends are fixed from translation but free to rotate.

<sup>2</sup>All capacities are based on AISC design method and testing.

<sup>3</sup>The length given for adjustable columns includes the maximum 4 inch projection of the screw assembly. (For example, the 76-inch-long adjustable column has a 72 inch long tube and a 4 inch long screw assembly.)

TABLE 3—LOAD CAPACITIES OF FIXED COLUMNS<sup>1,2</sup>

Dia (in)	3		3.5		3.5		3.5		4		4	
Nom, thickness (in)	0.12		0.12		0.216		0.216		0.12		0.226	
Design thickness (in)	0.112		0.112		0.201		0.201		0.112		0.210	
Fy (ksi)	42		42		33		42		42		42	
Capacity (kips)												
Max length (in)	LRFD $\Phi_c P_n$	ASD $P_a$	LRFD $\Phi_c P_n$	ASD $P_a$	LRFD $\Phi_c P_n$	ASD $P_a$	LRFD $\Phi_c P_n$	ASD $P_a$	LRFD $\Phi_c P_n$	ASD $P_a$	LRFD $\Phi_c P_n$	ASD $P_a$
72	28.3	18.8	36.1	24.0	51.5	34.3	62.4	41.5	43.7	29.1	79.2	52.7
75	27.6	18.4	35.4	23.6	50.7	33.7	61.1	40.7	43.1	28.7	78.0	51.9
78	26.9	17.9	34.7	23.1	49.9	33.2	59.9	39.8	42.4	28.2	76.8	51.1
81	26.1	17.4	34.0	22.6	49.1	32.6	58.6	39.0	41.8	27.8	75.6	50.3
84	25.4	16.9	33.3	22.2	48.2	32.1	57.3	38.1	41.1	27.4	74.3	49.4
87	24.6	16.4	32.6	21.7	47.3	31.5	56.0	37.3	40.4	26.9	73.0	48.6
90	23.9	15.9	31.9	21.2	46.5	30.9	54.7	36.4	39.8	26.4	71.7	47.7
93	23.1	15.4	31.1	20.7	45.6	30.3	53.4	35.5	39.0	26.0	70.4	46.8
96	22.3	14.9	30.4	20.2	44.7	29.7	52.0	34.6	38.3	25.5	69.0	45.9
99	21.6	14.4	29.6	19.7	43.8	29.1	50.7	33.7	37.6	25.0	67.7	45.0
102	20.8	13.9	28.9	19.2	42.8	28.5	49.3	32.8	36.9	24.5	66.3	44.1
105	20.1	13.4	28.1	18.7	41.9	27.9	48.0	31.9	36.1	24.1	64.9	43.2
108	19.3	12.9	27.4	18.2	41.0	27.3	46.6	31.0	35.4	23.6	63.5	42.2
111	18.6	12.4	26.6	17.7	40.0	26.6	45.2	30.1	34.7	23.1	62.1	41.3
114	17.9	11.9	25.9	17.2	39.1	26.0	43.9	29.2	33.9	22.6	60.7	40.4
117	17.2	11.4	25.1	16.7	38.1	25.4	42.5	28.3	33.2	22.1	59.3	39.4
120	16.5	11.0	24.3	16.2	37.2	24.7	41.2	27.4	32.4	21.6	57.8	38.5
123	15.8	10.5	23.6	15.7	36.2	24.1	39.9	26.5	31.6	21.0	56.4	37.5
126	15.1	10.0	22.9	15.2	35.3	23.5	38.6	25.7	30.9	20.5	55.0	36.6
129	14.4	9.6	22.1	14.7	34.4	22.9	37.3	24.8	30.1	20.0	53.6	35.7
132	13.8	9.2	21.4	14.2	33.4	22.2	36.0	23.9	29.4	19.5	52.2	34.7
135	13.2	8.8	20.7	13.8	32.5	21.6	34.7	23.1	28.6	19.0	50.8	33.8
138	12.6	8.4	20.0	13.3	31.6	21.0	33.4	22.2	27.9	18.5	49.4	32.8
141	12.1	8.0	19.3	12.8	30.6	20.4	32.2	21.4	27.1	18.0	48.0	31.9
144	11.6	7.7	18.6	12.4	29.7	19.8	31.0	20.6	26.4	17.5	46.6	31.0

For SI: 1 inch = 25.4 mm; 1 kip = 1000 lbf = 4.45 kN.

**Notes:**

<sup>1</sup>This is based on standard installation, which assumes that the ends are supported such that both ends are fixed from translation, but free to rotate.

<sup>2</sup>All capacities are based on AISC design method.

# TIGER BRAND<sup>®</sup> JACK POST<sup>®</sup>

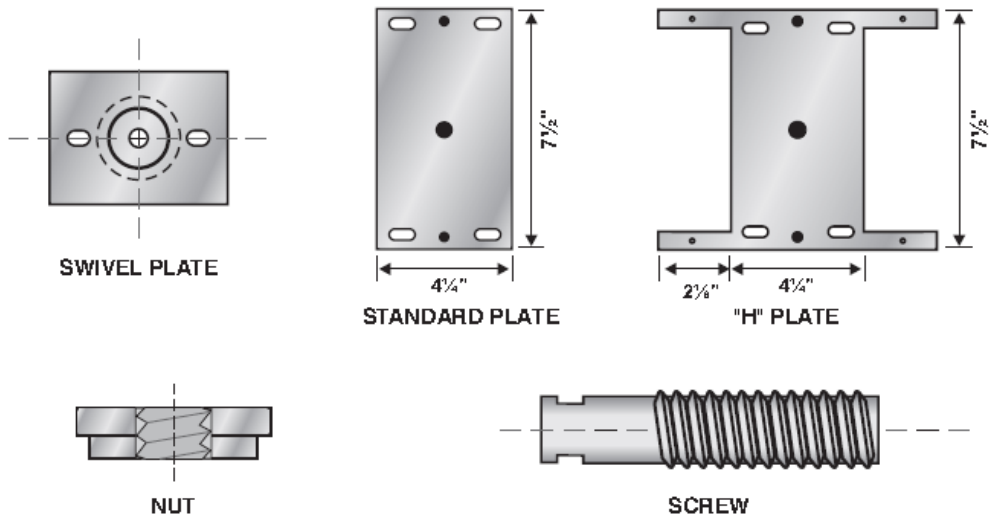
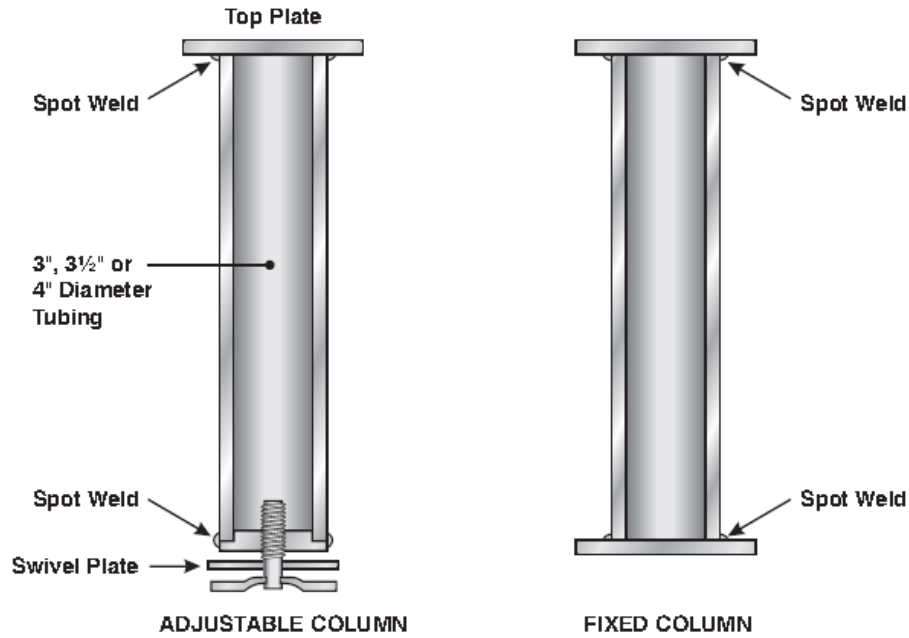

FIGURE 1

\*These drawings are for illustration purposes only. They are not intended for use as construction documents for the purpose of design, fabrication or erection.